



2019 CHAIRS  
& SOFAS

## COMFORT IS THE CONSTANT TREND

The chair you sit on to work at the office, a pouffe you spot for a flash face-to-face or the unit you rest at the lobby before you start your meeting... What is common about these in Zivella is comfort.

And of course, the functionality and sleek design fine-tuned according to your needs.

## SOFAS & ARMCHAIRS

Totem turns the lean approach into a design icon.



# TOTEM

Design by Alp Nuhoğlu, 2017

02



03



01

It is designed to bring movement and vitality to the space it is placed in, with its extraordinary look. Its captivating color choices make this design ready to take place in offices with character and stylish.

01. Silver Fabric  
02. Kiwi Fabric  
03. Bordeaux Fabric

Ada is a proud member of  
Retro design movement.



# ADA

Design by Alp Nuhoğlu, 2016



Its meticulously designed quilted details and solid wood legs gracefully carries the 60s style to our day. In executive offices, common areas or private houses, it draws attention in any space with its exclusive and colorful look.

01. Light Grey Fabric  
02. Pink Fabric  
03. Green Fabric  
Natural Polished Solid  
Wooden Legs



# KUZ

Design by Alp Nuhoğlu, 2016

Comfort designed with a grace and fineness rising from the harmony of solid wood and fabric.

Zivella created Kuz to add a touch of aesthetics with its lean lines to executive offices, lobby areas and private spaces.

Beige Fabric  
Solid Wood Legs





O2 Fabric, Massive Skeleton and Legs

Every space deserves elegance.



# KUZ-S

Design by Alp Nuhoğlu, 2017

With its dimensions, Kuz - S is created to adapt diverse spaces easily. Its smooth design makes it a perfect choice for various uses like an elegant resting space in private residences or a cozy corner in waiting halls.

01. Taupe Fabric  
Walnut Legs



# MANTA

Design by Setsu - Shinobu Ito, 2017



Genial, amiable and inviting.

Manta's exclusive design is gladly inviting you to a warm conversation. Born from the imagination of the world-famous designers, Setsu & Shinobu Ito, Manta represents the ease of communication with its comfortable and smooth form. It can be equipped with metal or wood legs according to your taste.

01. 16 Fabric  
02. 21 Fabric  
03. 12 Fabric  
Anthracite Metal Legs





# TUR

Design by Z Design Team, 2017



Tur is the support for your various needs in the office

Zivella Tur is created to be your biggest support during long meetings, with a high back.

01.26 Fabric  
02. 03 Fabric  
Anthracite Metal Legs





# NORD

Design by Alp Nuhoğlu, 2016

Attract all eyes  
in the office!



Nord is the center of attention with its strong look and enhances the sense of style with its sleek design. With details thoroughly calculated, such as the wooden lines completing the back of the chair, Nord provides a rich visual aesthetic from any angle.

Anthracite Fabric  
Anthracite Metal Legs



# JOY

Design by Z Design Team, 2016



01

02

## The feeling of belonging...

Joy is designed to give a positive and strong character to spaces and make communication easier with its solid look and elegance. Its natural curves and fluid design elements, Joy enhances the coziness of the room and feels like a home-like corner. It radiated the perfect integrity solid wood legs and with various pastel-toned color choices for the upholstery.

01. 03 Fabric  
01. 17 Fabric  
Beech Massive Legs

Make a strong impression.



# LISA

Design by Z Design Team, 2016



With its modern and fine lines, and elegant wooden legs, Lisa is perfect for executive offices. And if you think the common spaces needs a classy touch, Lisa is what you need.

01. 18 Fabric  
02. 26 Fabric  
Beech Massive Legs



Having a confident and happy attitude, Mod is created to enhance the mood in the new generation offices.



# MOD

Design by Alp Nuhoğlu, 2017



01



02

A center of attention with its cubic form and energetic design, Mod is available in various fabrics and colors, as well as wooden and metal leg options.

01. Curry Fabric  
02. Red Fabric  
Beech Massive Legs

A special space.



# VENI & VENI-S

Design by Z Design Team, 2018



Veni-S has an exclusive presence with its modern design. With its high body and armrests enfolding the person, it radiates a friendly and sincere air. Achieving perfect harmony with its metal legs, Veni-S is ideal for creating an exclusive corner in offices and waiting halls.

- 01. 12 Fabric
- 02. 15 Fabric
- Anthracite Metal Legs



# NEO

Design by Alp Nuhoğlu, 2017

Strong, bold, and cozy and hearty as well.

Neo perfectly fits into the new generation work spaces with its powerful design that is based on a minimalistic geometry. Neo is created to attract all the glazes, wherever it is placed.

Mustard Fabric  
Anthracite Metal Legs





The gentle and perfect combination of metal and leather...



# REN

Design by Alp Nuhoğlu, 2016



With its special design giving a deep sense of refinement and richness, Ren is ideal to meet the needs of comfort in executive offices furnished with elaboration.

Black Leather  
Stainless Steel Legs



Through leanness, Plaza is designed to provide comfort in any size.



01



02



# PLAZA

Design by Alp Nuhoğlu, 2017

It fits in any space with its timeless look, and gives functionality with its movable table attachment.

01. 27 Fabric  
02. 25 Fabric



LIA

Design by Z Design Team, 2017

Lia is a retro-modern.



01



02



03

It offers a cozy style that combines the lines of the past with today's modern understanding. It easily fits in various spaces with colorful fabric alternatives, and metal or wooden leg options.

- 01. Anthracite Fabric, Transmission Legs
- 02. Blue Fabric, Oak Solid Legs
- 03. Anthracite Fabric, Oval Profile Metal Legs

Concentrating has never been easier!



Available in high, low, single and double, Sofa is created with dynamically in order to provide a rich aesthetic along with its comfort. the high-back option designed specifically to create a small but private area that allows the user to concentrate even in crowded spaces.

01. 02 Fabric  
02. 12 Fabric  
Anthracite Metal Legs

A reliable retreat with a positive aura and character...



POZ

Design by Alp Nuhoğlu, 2016



The natural wooden back detail gives Poz a warm yet eye-catching visual touch. The sofa design which enables a closer communication also provides comfort with leather and fabric alternatives.

Black Real Leather  
Wooden Back  
Anthracite Metal Legs



It is a conformist!



YAKA

Design by Alp Nuhoğlu, 2016



Standing out with its lean design, Yaka is created to be an office chair that adapts to its surroundings with its timeless line. Open for different combinations, Yaka's super power is being the most comfortable corner of the office or even a lobby.

Black Fabric  
Anthracite Metal Legs

Smooth, striking and innovative.



KOZA

Design by Alp Nuhoğlu, 2018



With its smooth yet powerful design, Koza is always the star of your space. Achieving to present simplicity with comfort with perfect integrity, Koza is created to radiate an innovative and modern air especially with its vibrant colors.

26 Fabric  
Chrome Legs

The noble look.



# LERON

Design by Alp Nuhoğlu, 2017

Its wide and deep design gives Leron a truly noble look and makes it stand out with the lean lines that complete the design. Available in single or double, Leron adapts to different styles with a wide range of color alternatives in fabric.

133 Fabric  
Anthracite Metal Legs

The perfect line of simplicity!



# HAZAL

Design by Z Design Team, 2016



01



02

Hazal has a naïve and lean look with its carefully considered details. It is beyond trends, and created to easily fit in. And most importantly, it is as comfortable as it is lean.

- 01. 133 Fabric  
Anthracite Metal Legs
- 02. 133 Fabric  
Solid Gray Birch Wooden Legs



Feeling at home everywhere.



# BASIC

Design by Kağan Akay, 2018

With Basic's comfortable and inviting design, you can feel at home in offices or waiting halls. Its curved body providing extra comfort and smooth lines are the most important features distinguishing Basic from others...

131 Fabric  
Chrome Legs

Mola is calm and coherent in a nut shell.



# MOLA

Design by Alp Nuhoğlu, 2016



Its special design that enables various sitting arrangements possible makes Mola an essential part of open concept offices, which have to be flexible according to changing needs. It is extremely productive with its design allowing it to make as many special combinations as possible.

01. Anthracite Fabric  
Anthracite Metal Legs

Single, double, triple or with even more seats  
in offices or lobbies...



# PAY

Design by Alp Nuhoğlu, 2016



The more Pay placed side by side, the more colorful it becomes. Pay has a modular, cheerful and functional design that can be combined infinitely and just according to your needs.

01. 24 Fabric  
02. 12 Fabric  
03. 23 Fabric  
Anthracite Metal Legs

Bük is created to be a team player in any space



# BÜK

Design by Alp Nuhoğlu, 2017



It can be used in various purposes and forms with its fluid and modular design. And this makes Bük an ideal solution for lobbies to provide a great rest.

124 Fabric  
Anthracite Metal Legs





A comfortable  
and serene corner.



Radiating a cordial mood to the space with its stance and vivacity, Tuna is designed to create a comfortable corner in offices or waiting halls. Providing a sweet harmony especially with warm colors, Tuna can be used for different purposes with its armrest and separate puff .

16 Fabric  
Anthracite Metal Legs

Everything in harmony and integrity.



With extra modules such as the pouffe and coffee table, Tuna family becomes a winner especially for lobbies.

The convex and concave modules are ideal to create continuity in spaces. Giving the user freedom, Tuna stands out with its openness for creativity.

01. 19 Fabric  
02. 03 Fabric  
Anthracite Metal Legs



# SALT

Design by Alp Nuhoğlu, 2016

Every detail in Salt has been designed with refinement



It completes the space with its lean line through thin armrests and modern design. Available in single, double or corner options, Salt is ideal especially for small spaces.

01. 07 Fabric  
Anthracite Metal Legs



An ideal corner for  
more communication.



# SALT CORNER

Design by Alp Nuhoğlu, 2017

Salt has an elegant and timeless design, and provides a perfect solution for offices and lobbies, with its adaptable dimensions.

01. 23 Fabric  
Anthracite Metal Legs





# ZEN

Design by Burak Koçak, 2017

A group to rest.



Zen is designed specifically create a real recreational area in the offices and lobbies, with its lean and integral design. With its five different sizes available, Zen brings a soft and calm touch to spaces.

01. Silver Fabric  
02. Anthracite Fabric



Differentiating is never that easy.



# BEAM

Design by Oğuzhan Abdik, 2017

When the natural aurora of solid wood is combined with modern design, the result is very striking and sympathetic. Beam is ideal to transform any wall front into a design corner.

01. Black Leather  
Oak Solid Body





# KUKA BENCH

Design by Alp Nuhoğlu, 2018



01. 22 Fabric



Every detail in Kuka Bench is designed to meet all the needs of the communication age.

The tiny charging unit, which is in harmony with the design of the bench makes life much easier.



The new generation  
of modular design.

## Colorful, dynamic and cheerful...

Kuka Bench brings dynamism and energy to where it is placed. Even more cheerful with various color combinations, Kuka Bench radiates positive energy with its joyful character.

Its modular structure and various color combination options gives room to creativity in spaces, while providing a high level of comfort, along with a cheerful and modern design.

Available also with a back support, Kuka Bench offers an ergonomic sitting experience.





## THE ANATOMY OF COMFORT

Zivella knows how important health and comfort is, and how they are inseparable from each other. Each chair the company imagines and creates is a manifestation of this idea. Ergonomic features that are carefully considered with a people-oriented approach, upholsters and details that reflect our high quality standards are what you will find in Zivella's office chairs and chairs.

# CHAIRS

Mody is enhanced with a special cast to last long.



# MODY

Design by Z Design Team, 2016

It provides an uninterrupted comfort with its specially designed back and armrests. Considering its compact design and minimal size, it is perfect for small lobbies.

01. Metal Transmission Legs  
02. Chrome Metal Star Legs  
Anthracite Fabric

Appealing to a refined sense of style.



# NORD CHAIR

Design by Alp Nuhoğlu, 2017



Nord chair is a unique combination of metal, wood and fabric. Providing a freedom of movement with its wheeled legs, the ergonomically designed chair is ready to face the difficulties of a busy work life.

Silver Fabric  
Chrome Metal Legs



# MAY

Design by Alp Nuhoğlu, 2018

Modern and upbeat.



01



02



03

With its vibrant and dynamic form, May is designed in line with the characteristics of today's new generation workspaces and offices. Its body providing a comfortable sitting experience, moving metal legs and convenient arm rests make it an ideal chair for long-term use. Furthermore, May stands out in an otherwise ordinary office environment especially with its lively fabric colors.

01. 11 Fabric  
02. 23 Fabric  
03. 24 Fabric  
Anthracite Metal Legs



Some designs grace the space.



MAYA

Design by Alp Nuhoğlu, 2018



The harmonious association of fabric and wood is the most important characteristic of Maya. With its soft and round lines reflecting modern design approach, Maya is the best choice for the ones desiring to make a difference in space.

15 Fabric  
Metal Legs



# ORBIT

Design by Alp Nuhoğlu, 2018

Modern and elegant.



Orbit's character incorporates the design lines of next generation offices. Standing out with its round lines, comfortable sitting and simplicity, Orbit creates new forms through its different wheeled leg options.

Kiwi Fabric  
Anthracite Metal and  
Aluminium Legs





# SAR

Design by Alp Nuhoğlu, 2018

Its character radiates coziness.



With its deep seating and body embracing from both sides, Sar is extremely comfortable and inviting. It is possible to create warm and friendly waiting spaces in all kinds of venues. Different leg alternatives make Sar adaptable to various utility purposes.



Curry Fabric  
Wooden and Metal Legs



# BEST

Design by Z Design Team, 2018

Comfortable, simple and practical.



Best is the embodiment of the finest features that an office chair is expected to include. Provided with moving or fixed legs for different purposes, optional arm rests can also be added to this functional office chair. Giving a modern and harmonious feeling with its metal legs and fabric upholstery, Best adapts to every space perfectly with its ideal size.

01. 15 Fabric  
02. 22 Fabric  
03. 21 Fabric  
Anthracite Metal Legs





# ESE

Design by Z Design Team, 2017



01

02

03

Ese Family is designed to completely support the body, and specifically to provide the ideal comfort even during long sitting requirements.

- 01. Chrome Star Legs
- 02. Chrome Star Legs
- 03. Chrome Star Legs, 26 Fabric



Comfort is  
a part of design.

With colorful fabric surfaces  
and metal body details, Ese office chairs  
are great for any kind of new generation  
working space.







# KUKA OTTOMAN

Design by Alp Nuhoğlu, 2016



## A new design movement!

Kuka Ottoman easily fits in any space with its movable nature. Its gracefully designed sitting surface is available both in fabric and leather. And it can be easily replaced in the office with leather handle and hidden wheels.

# TOY

Design by Alp Nuhoğlu, 2018



The source of joy for offices.



With its modern and extraordinary lines, Toy is ready to cheer up your office environment. Toy's aesthetic, simple and smiling design makes it the perfect object that lightens the mood in a busy work day.

- 01. Curry Fabric
- 02. Red Fabric
- 03. Pink Fabric
- 04. Anthracite Fabric





# IKA STOOL

Design by Alp Nuhoğlu, 2017

New trend:  
Working standing up

Ika is a symbol of the new trend rising globally. Differentiating with its design enabling a high sitting, Ika is the perfect choice for standing up meetings or conversations.

Green Fabric  
Oak Wooden Legs



Ergonomy and comfort.



# ROY STOOL & CHAIR

Design by Z Design Team, 2016



Roy's design is enhanced with a special molding on the sitting surface and back that provides an ergonomic comfort. And its thin metal legs carry it to a higher level with strength and elegance. With adjustable leg length, Roy is an ideal solution for both seminar halls and cafés, as well as tiny lobbies.

01. 26 Fabric  
02. 18 Fabric  
03. 10 Fabric  
Anthracite Metal Profile Legs

FACT SHEETS

# TOTEM ARMCHAIR



- \* Over metal carcass polyurethane monobloc cast foam body & cushion.
- \* Artificial leather - fabric options.

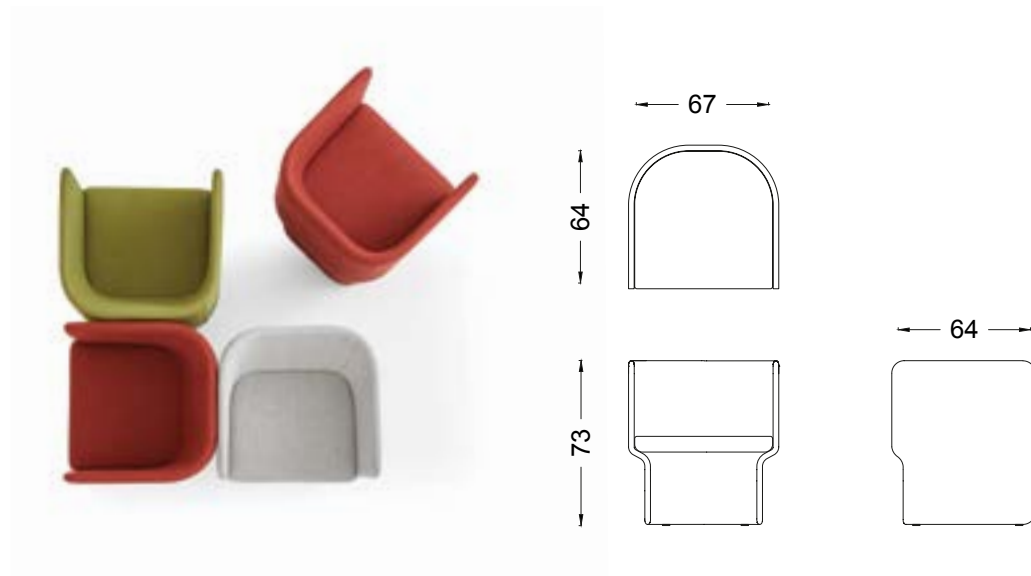

# ADA ARMCHAIR



- \* Over metal carcass polyurethane monobloc cast foam body & cushion.
- \* Polished OAK massive legs. (on the BRK1450)
- \* Polished BEECH massive or lacquered paint wood leg (on the BRK1451 model)
- \* Artificial leather - fabric options.

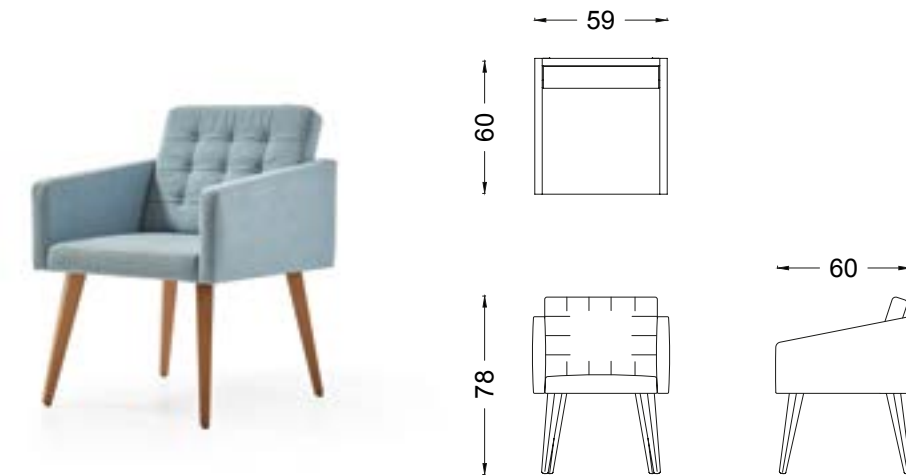



# PAY CHAIR



- \* Beech massive skeleton.
- \* Elektrostatic paint coating 17mm diameter cnc twist metal leg.
- \* Back& seat 32DNS soft grey foam.
- \* Artificial leather - fabric options.

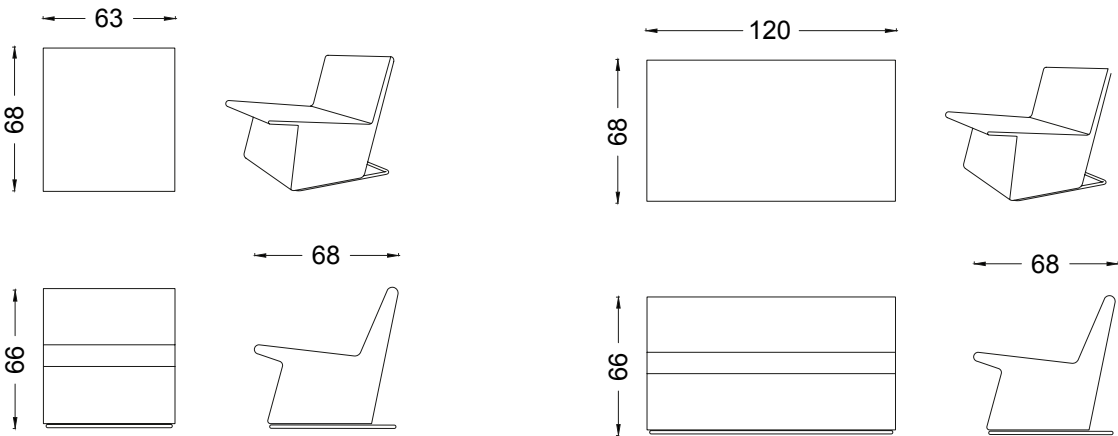

# TUR ARMCHAIR



- \* Over metal carcass polyhuretane cast foam body&cushion.
- \* Electrostatic paint or chrome coating metal profile leg.
- \* Artificial leather - fabric options.

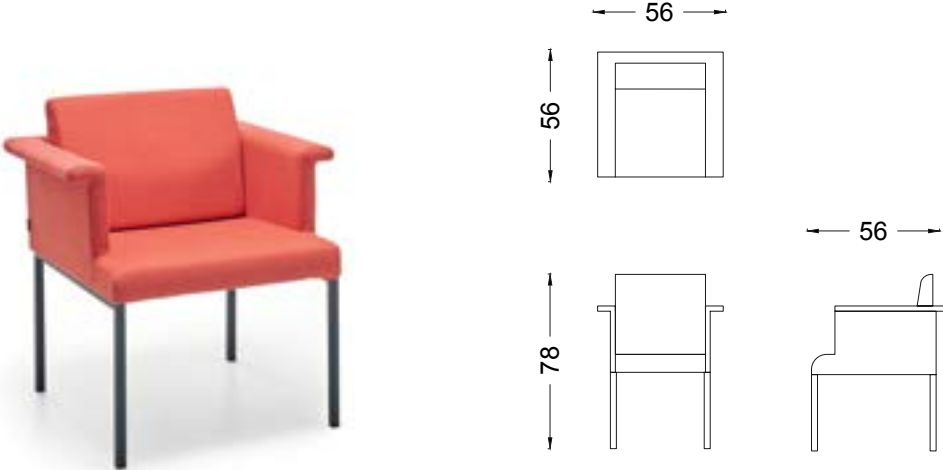

# MOD CHAIR



- \* Over metal carcass polyurethane monobloc cast foam body & cushion.
- \* Elektrostatic paint cnc cutting metal llama leg.
- \* Polished beech massive leg. (On the Mod Vera models)
- \* Artificial leather - fabric options.

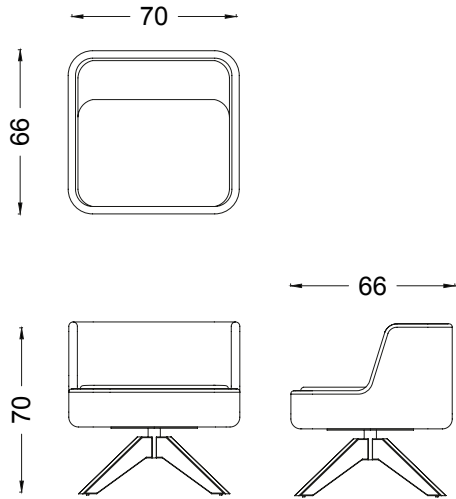

# MANTA CHAIR



- \* Over metal carcass polyurethane monobloc cast foam body.
- \* Electrostatic paint cnc cutting base metal sheet.
- \* Artificial leather - fabric options.

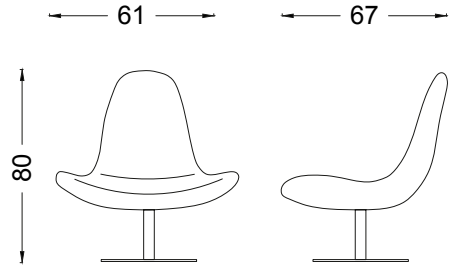

# NORD CHAIR



- \* Over metal carcass polyurethane monobloc cast foam body & cushion.
- \* Elektrostatic paint cnc cutting metal llama leg.
- \* Polished milling cutter oak veneered plywood panel back.
- \* Polished beech massive leg. (On the Nord Vera models)
- \* Artificial leather - fabric options.



# MODY ARMCHAIR



- \* Adjustable height chrome or static paint metal cnc twist with five leg.
- \* 2 Position Tilt mechanism.
- \* Artificial leather or fabric upholstery monobloc polyurethane cast foam.



# LISA ARMCHAIR



- \* Cnc twist metal transmission skeleton.
- \* 32DNS soft grey foam monoblock body with upholstery.
- \* Feather foam upholstery back.
- \* Polished beech massive leg.
- \* Artificial leather - fabric options.

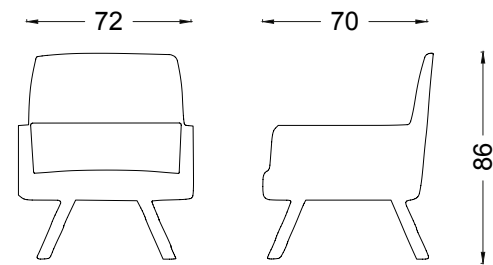

# JOY BERGÈRE



- \* Over metal carcass polyurethane monobloc cast foam body & cushion.
- \* Elektrostatic paint cnc cutting metal llama leg.
- \* Polished milling cutter oak veneered plywood panel back.
- \* Polished beech massive leg. (On the Nord Vera models)
- \* Artificial leather - fabric options.

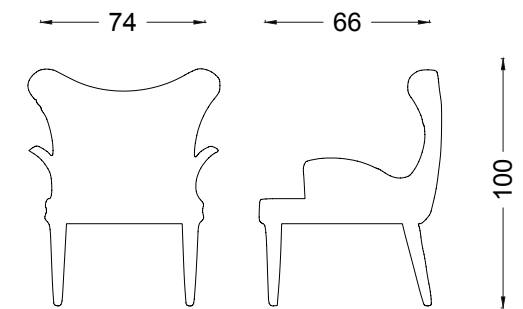



# VENI-S BERGÈRE



- \* Interior construction beech massive.
- \* electrostatic paint coating, diameter 25mm,1,5mm thickness cnc twisted round pipe metal legs.
- \* 32DNS soft gray seat and back foam.
- \* 25 DNS soft feathered waist foam.
- \* Artificial leather - fabric options.

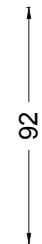
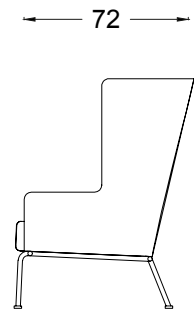
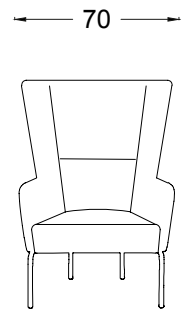

# VENI BERGÈRE



- \* Interior construction beech massive.
- \* electrostatic paint coating, Diameter 25mm,1,5mm thickness cnc twisted round pipe metal legs.
- \* 32DNS soft gray seat and back foam.
- \* 25 DNS soft feathered waist foam.
- \* Artificial leather -fabric options.

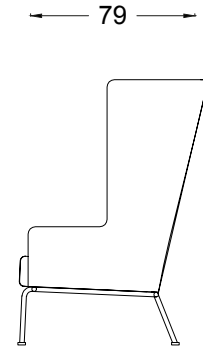
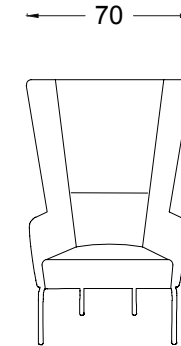

# MOLA SOFA



- \* Polished milling cutter oak venerated plywood paper back.
- \* Beech massive skeleton.
- \* Elektrostatic paint coating 17mm diameter outside construction.
- \* Back& seat 32DNS soft grey foam.
- \* Artificial leather - fabric options.



# KUKA SOFA



- \* Beech massive skeleton.
- \* Polished beech massive turning machine wood legs.
- \* Back& seat 32DNS soft grey foam.
- \* Artificial leather - fabric options.

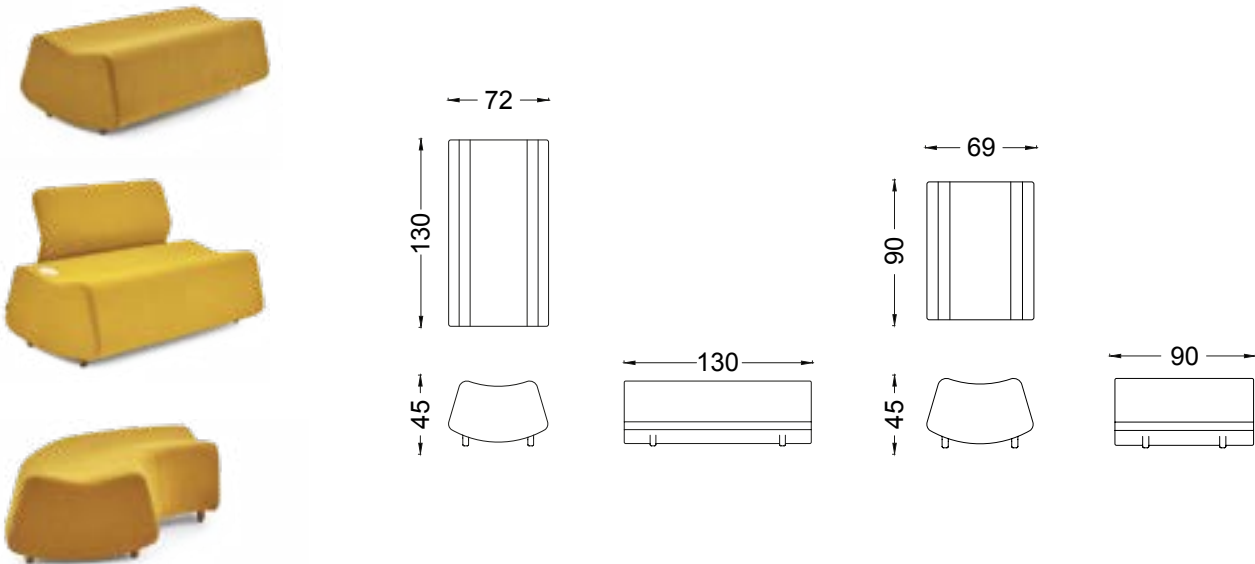
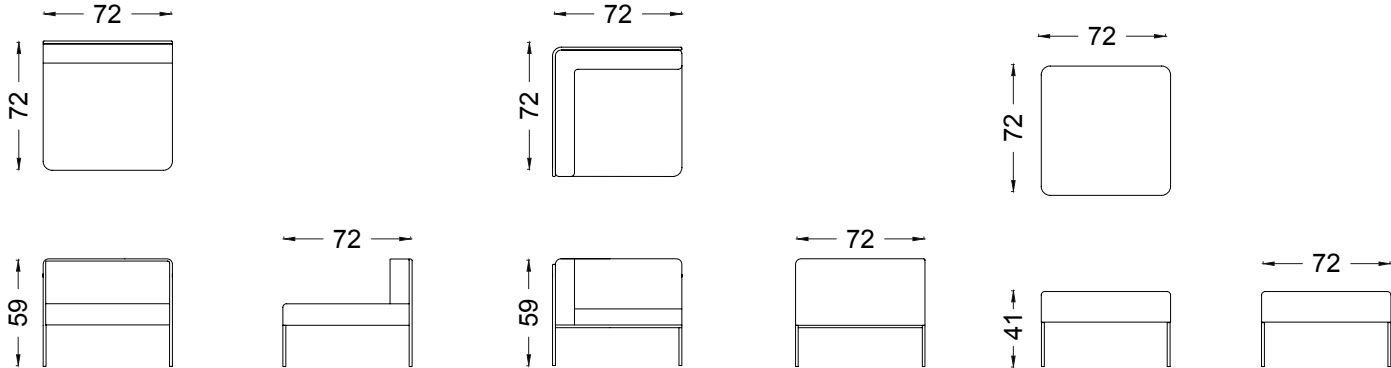

# SALT

## SOFA & ARMCHAIR



- \* Beech massive skeleton.
- \* Metal profile leg , elektrostatic paint or chrome coating.
- \* Artificial leather - fabric options.

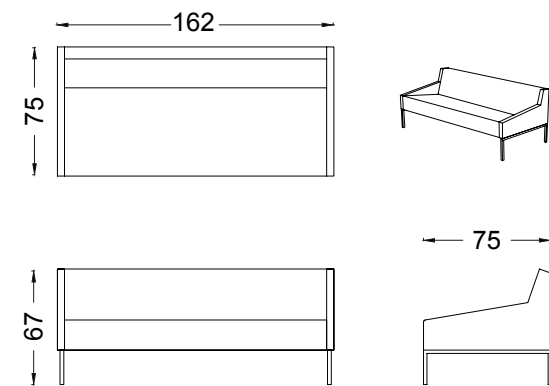
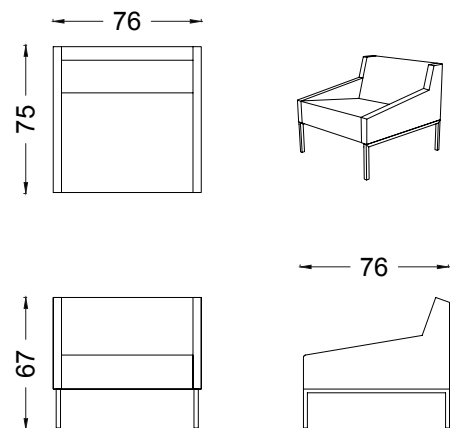

# SALT

## SOFA



- \* Beech massive skeleton.
- \* Metal profile leg, electrostatic paint or chrome coating.
- \* Artificial leather - fabric options.

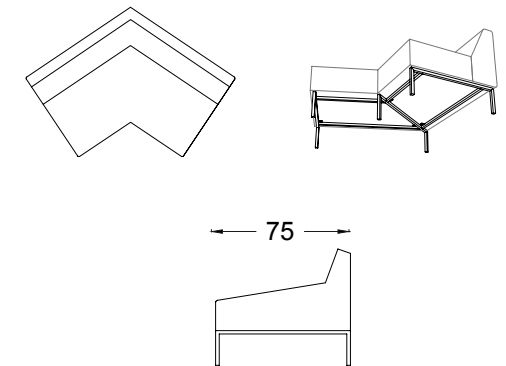

# TONE SOFA



- \* Beech massive skeleton.
- \* 25mm dia meter round pipe elektrostatic paint coating metal leg.
- \* Cnc cutting feather foam back.
- \* 32DNS soft grey foam seat .
- \* Polished milling cutter oak venerated side table.
- \* Artificial leather -fabric options.

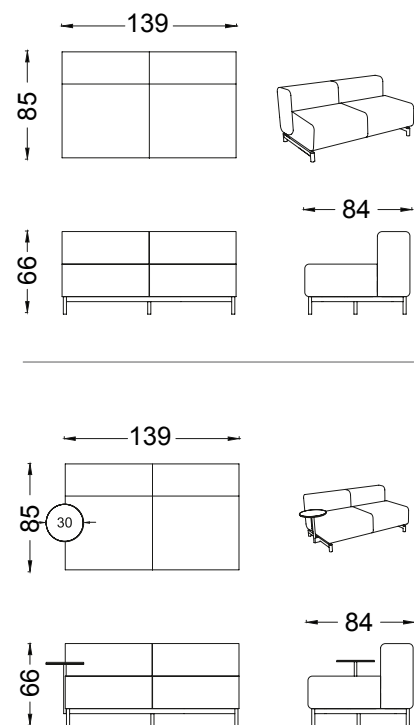

# TONE SOFA



- \* Beech massive skeleton.
- \* 25mm dia meter round pipe elektrostatic paint coating metal leg.
- \* Cnc cutting feather foam back.
- \* 32DNS soft grey foam seat.
- \* Artificial leather - fabric options.

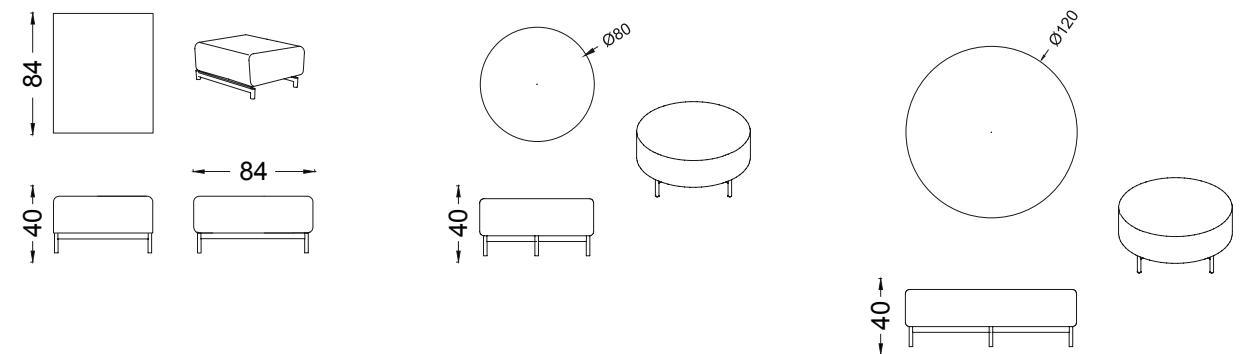



# ZEN BENCH



- \* Beech massive & plywood skeleton.
- \* 32DNS soft grey foam seat&back.
- \* Adjustable metal bingo leg.
- \* Artificial leather - fabric options.

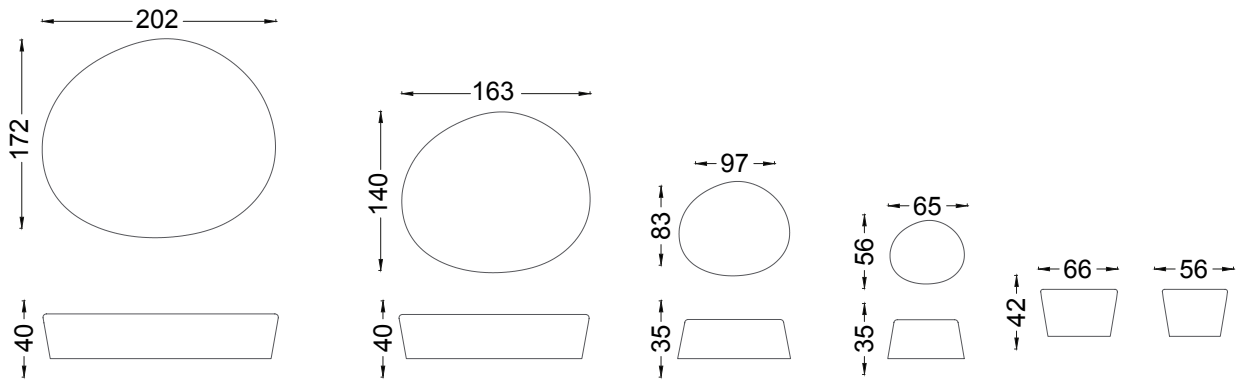

# BEAM BENCH



- \* All wood parts oak massive.
- \* 32DNS soft grey foam seat&back.
- \* Artificial leather - fabric options.

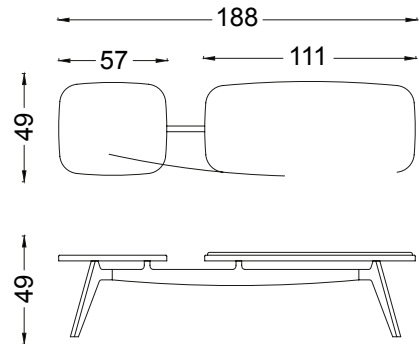

# NEO SOFA



- \* Beech massive skeleton.
- \* Elektrostatic painted cnc cutting metal llama leg.
- \* Back& seat 32DNS soft grey foam.
- \* Artificial leather - fabric options.

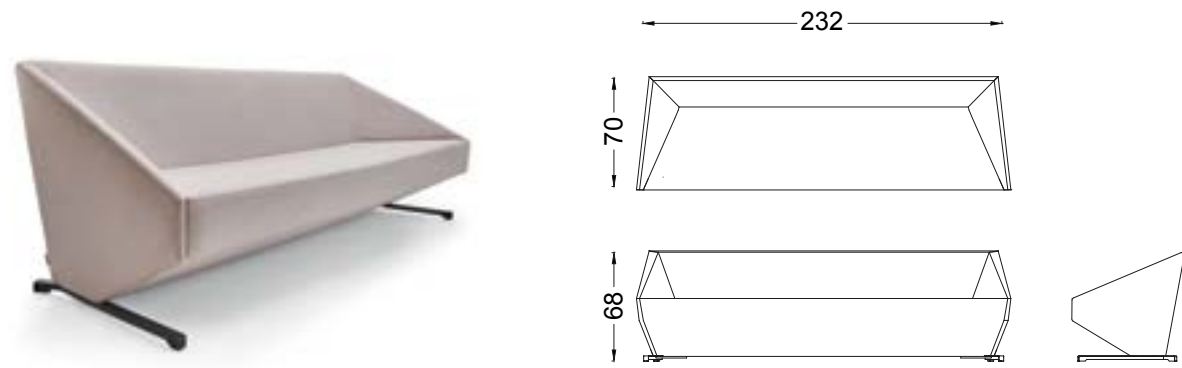

# POZ SOFA



- \* Beech massive skeleton.
- \* Milling cutter oak veneered back wood.
- \* Metal profile leg , elektrostatic paint or chrome coating.
- \* Artificial leather - fabric - genuine leather options.

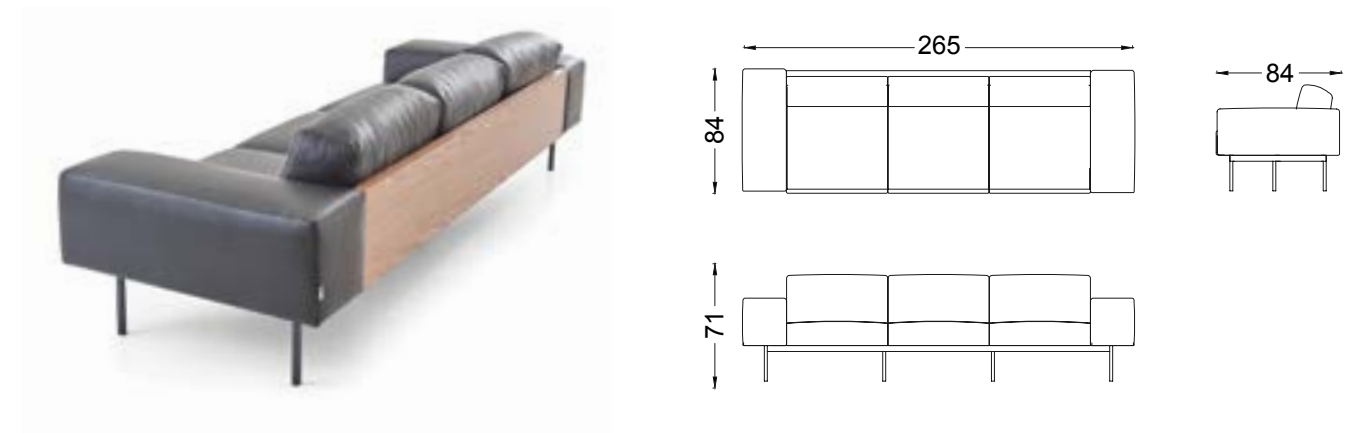

# REN SOFA & ARMCHAIR



- \* Metal construction.
- \* Metal profile leg with Bronze coating.
- \* Silicon back cushions.
- \* Artificial leather - fabric - genuine leather options.

# KOZA SOFA



- \* Interior construction beech massive.
- \* Electrostatic paint or chrome plated diameter 22mm 1.5mm thick metal pipe legs.
- \* Back and session 32DNS soft gray foam.
- \* Artificial leather - fabric options.

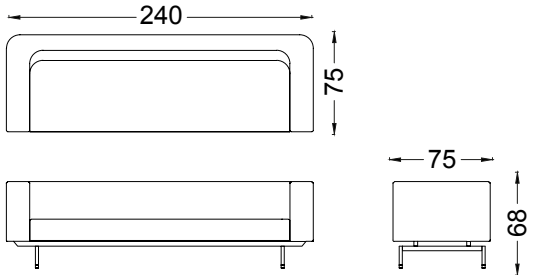
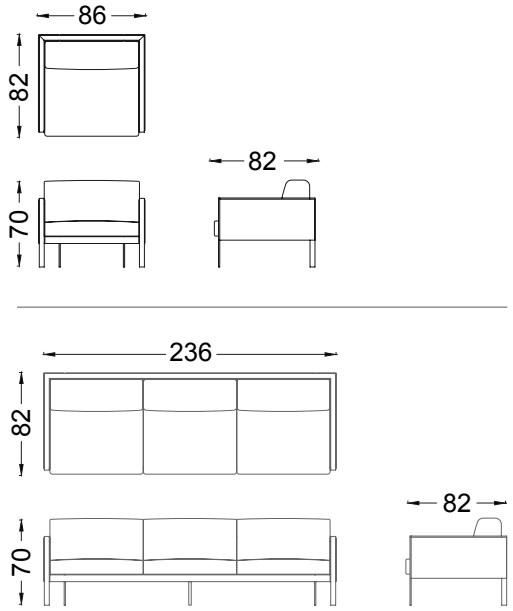

# YAKA SOFA & ARMCHAIR



- \* Beech massive skeleton.
- \* Metal profile leg , elektrostatic paint or chrome coating.
- \* Artificial leather -fabric options.
- \* Feather foam & seat & cushions for back.

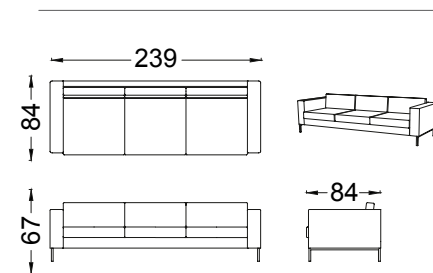
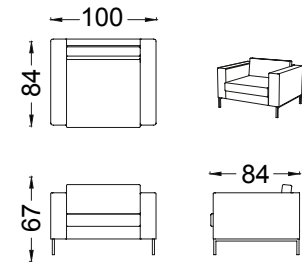

# BASIC SOFA & ARMCHAIR



- \* Interior construction beech massive.
- \* Electrostatic paint or chrome plated adjustable height, diameter 22mm 1.5mm thickness metal pipe legs.
- \* 32DNS soft gray foam over 25DNS feather foam seat.
- \* 25 DNS soft feathered foam back.
- \* Artificial leather -fabric options.

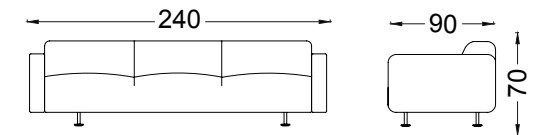
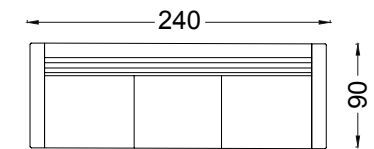



# PARK SOFA & ARMCHAIR



- \* Cnc twist 22mm dia meter metal pipe inside construction.
- \* 19\*2mm cnc twist elektrostatic paint metal legs.
- \* Silicon back cushions.
- \* Back& seat 32DNS soft grey foam.
- \* Artificial leather - fabric options.

# HAZAL SOFA



- \* Beech massive skeleton.
- \* Polished beech massive leg for the sofa.
- \* Back&seat 32DNS soft grey foam.
- \* Artificial leather - fabric - genuine leather options.

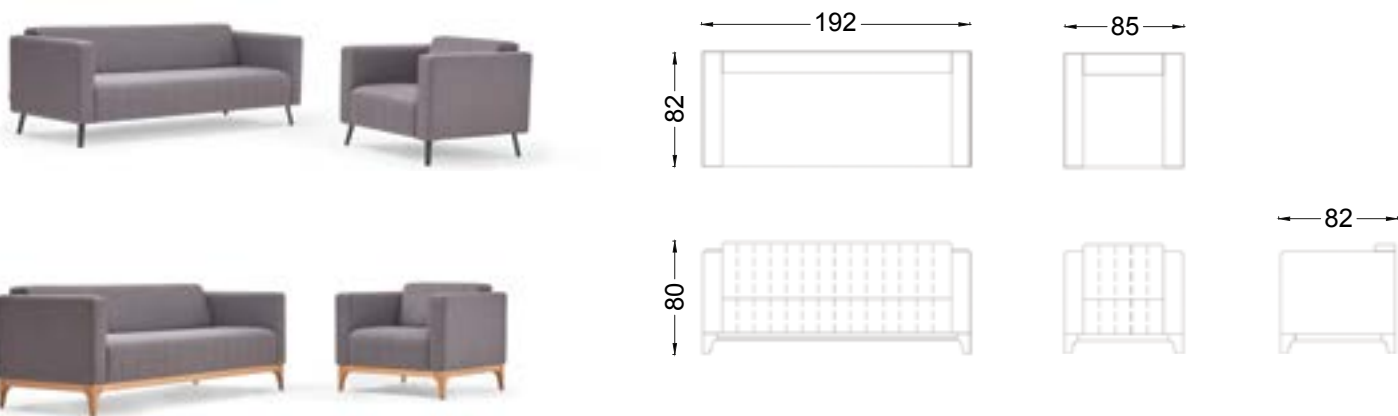
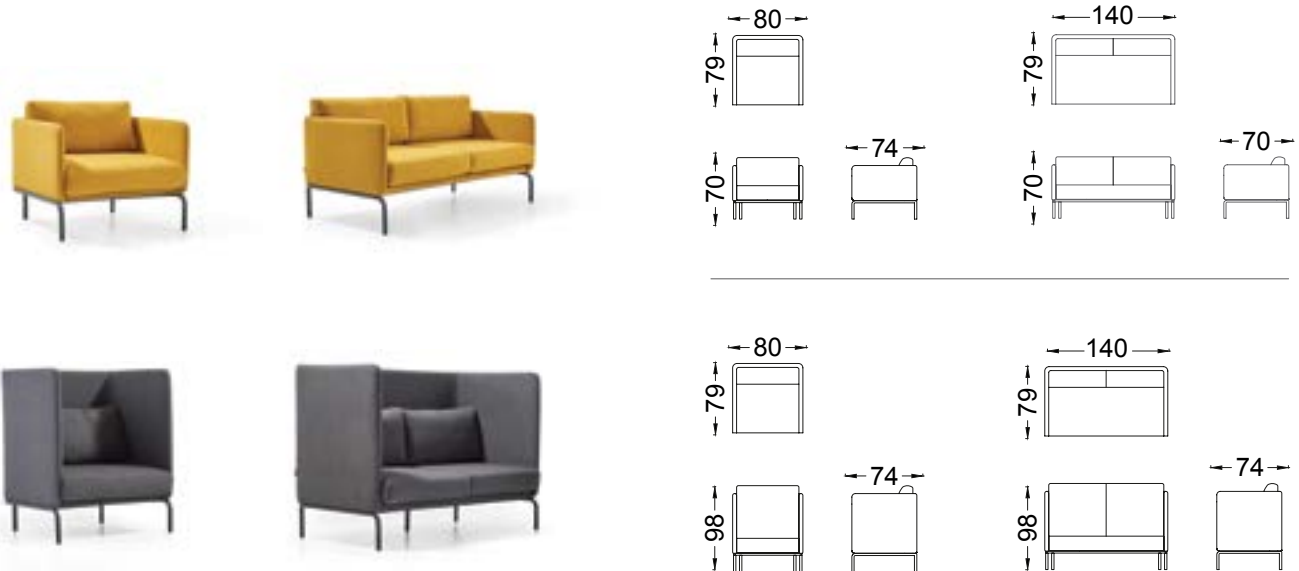

# LERON

SOFA  
& ARMCHAIR

# PLAZA

SOFA  
& ARMCHAIR



- \* Beech massive skeleton.
- \*Sofa arms upholstery over metal profile.
- \* Elektrostatic paint or chrome coating metal llama legs.
- \* Back& seat 32DNS soft grey foam.
- \* Artificial leather - fabric - genuine leather options.

- \* Beech massive skeleton
- \* Elektrostatic paint or chrome coating metal llama legs
- \* Back& seat 32DNS soft grey foam.
- \* Artificial leather - fabric options.
- \* 25cm diameter 8mm melamine demount side table.

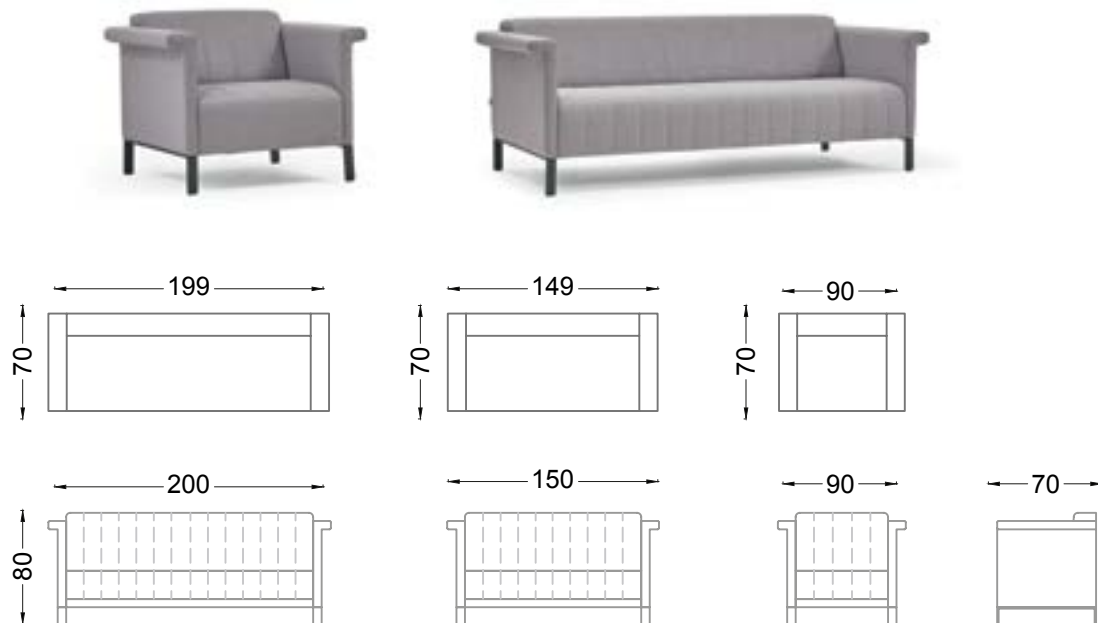

# KUZ SOFA



- \* Beech massive skeleton.
- \* Polished OAK massive arm & leg wood.
- \* Feather cnc cutting foam cushions for back.
- \* Back& seat 32DNS soft grey foam.
- \* Artificial leather - fabric options.

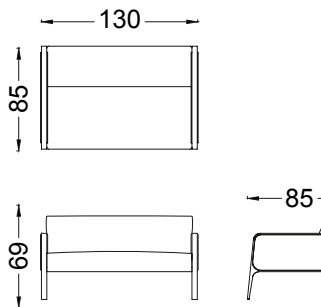
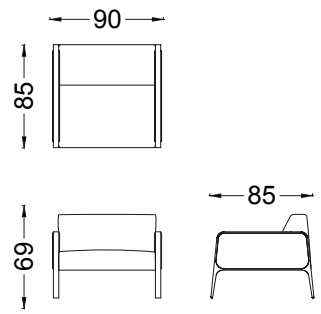

# KUZ-S ARMCHAIR



- \* Beech massive skeleton.
- \* Polished OAK massive arm & leg wood.
- \* Feather cnc cutting foam cushions for back.
- \* Back& seat 32DNS soft grey foam.
- \* Artificial leather -fabric options.

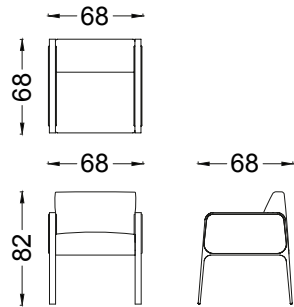

# BÜK SOFA



- \* Beech massive skeleton.
- \* Back& seat 32DNS soft grey foam.
- \* Construction inside metal support llamas
- \* Elektrostatic painted cnc cutting metal llama leg.
- \* Artificial leather - fabric options.

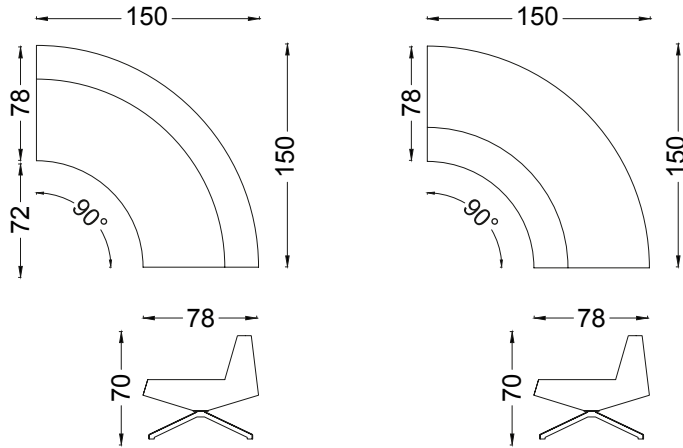

# NORD CHAIR



- \* Polished milling cutter oak veneered plywood papel back.
- \* Adjustable height chrome or static paint metal cnc twist with five leg.
- \* 2 Position Tilt mechanism.
- \* Artificial leather or fabric upholstery monobloc polyhuretane cast foam.

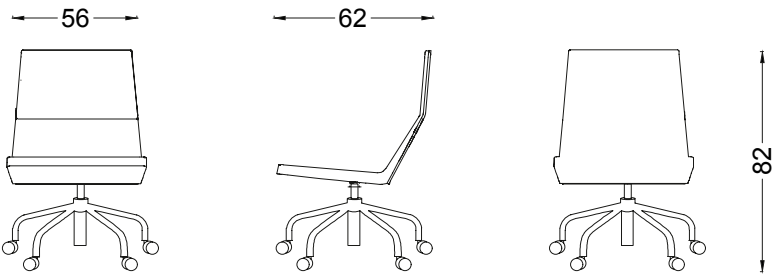



# LIA ARMCHAIR



- \* Cnc twist Metal transmission skeleton .
- \* 32DNS soft grey foam monoblock body with upholstery.
- \* Rotary elektrostatic paint coating oval profile metal leg.
- \* Elektrostatic paint or chrome coating metal transmission leg.
- \* Polished beech massive leg.
- \* Artificial leather - fabric options.

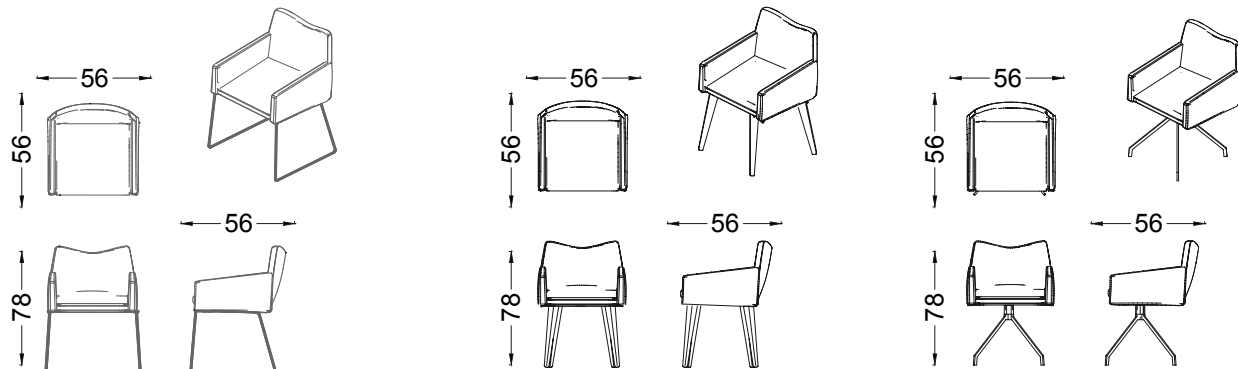

# ESE CHAIR & ARMCHAIR



- \* Height adjustable chrome or electrostatic painted metal star feet.
- \* Single-lever tilt mechanism that provides up-down movement.
- \* Chrome or electrostatic coating diameter 16mm thickness cnc twist pipe metal arms.
- \* Plywood paper monoblock body with artificial leather or fabric upholstered.

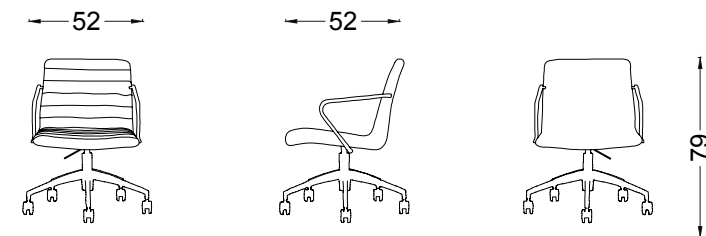

# MAY ARMCHAIR



- \* Electric paint coated or matt anodized aluminum injection star feet with height adjustment. (May study model)
- \* Electrostatic painted metal four feet with plastic moving wheels. (May meeting model)
- \* Single-arm Tilt mechanism that allows up-down movement.
- \* Artificial leather or fabric upholstered metal carcass on cast polyurethane body and head.

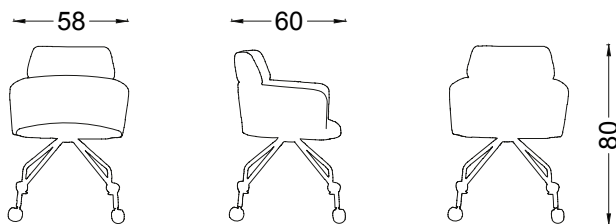
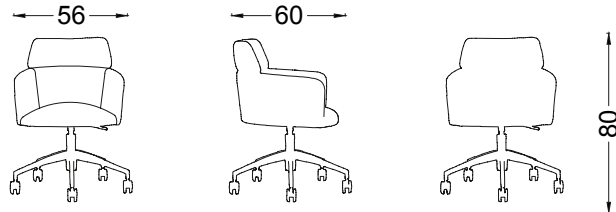

# MAYA ARMCHAIR



- \* Electric paint coated or matt anodized aluminum injection star feet with height adjustment. (May study model)
- \* Electrostatic painted metal four feet with plastic moving wheels. (May meeting model)
- \* Single-arm Tilt mechanism that allows up-down movement
- \* Artificial leather or fabric upholstered metal carcass on cast polyurethane body and head
- \* Polished milling cutter oak veneered plywood paper head back.

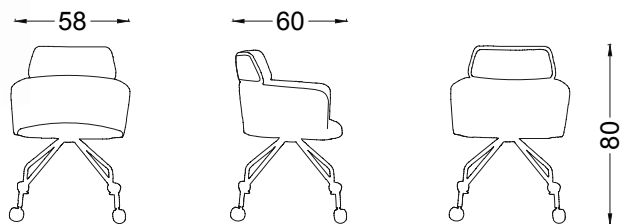
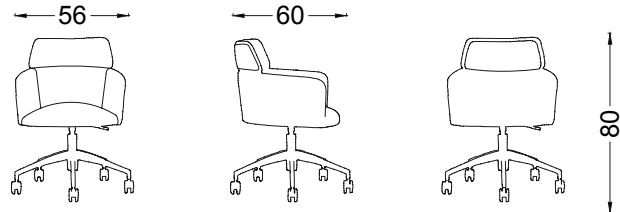

# BEST CHAIR & ARMCHAIR



- \* Height adjustable chrome or electrostatic painted metal star feet. (Best working model)
- \* Single-lever tilt mechanism that provides up-down movement.
- \* Electrostatic painted or chrome plated aluminum injection fixed arm. (Best working model)
- \* Electrostatic painted diameter 28mm thickness cnc twist pipe wheel metal feet. (Best guest model)
- \* PP plastic fixed arm integrated into metal skeleton. (Best guest model)
- \* Electrostatic paint or chrome plating diameter 12mm thickness cnc twist transmission metal foot. (Best chair model)
- \* Artificial leather or fabric upholstered polyurethane monoblock.

# SAR ARMCHAIR



- \* Adjustable height chrome or static paint metal 19 mm pipe with five leg. (Sar working model)
- \* Single-arm Tilt mechanism that allows up-down movement. (Sar working model)
- \* Electrostatic painted metal four feet with plastic moving wheels. (Sar meeting model)
- \* Electrostatic painted metal four feet w/o wheels. (Sar waiting model)
- \* Polished beech massive leg. (Sar waiting wooden leg model)
- \* Artificial leather or fabric upholstered metal carcass on cast polyurethane body.

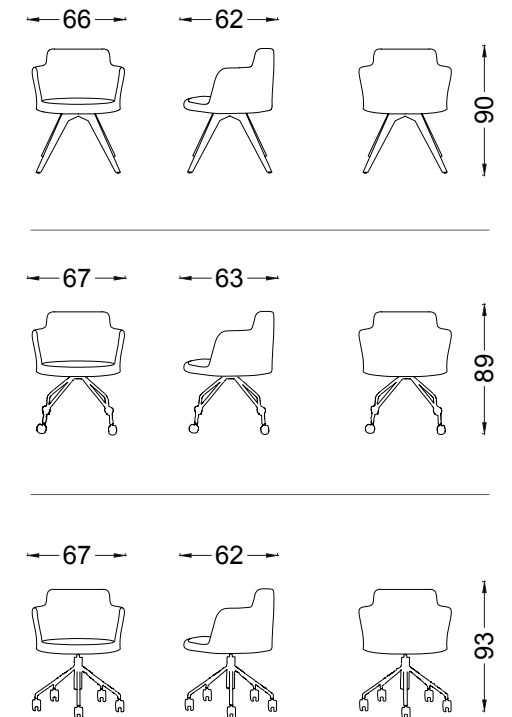
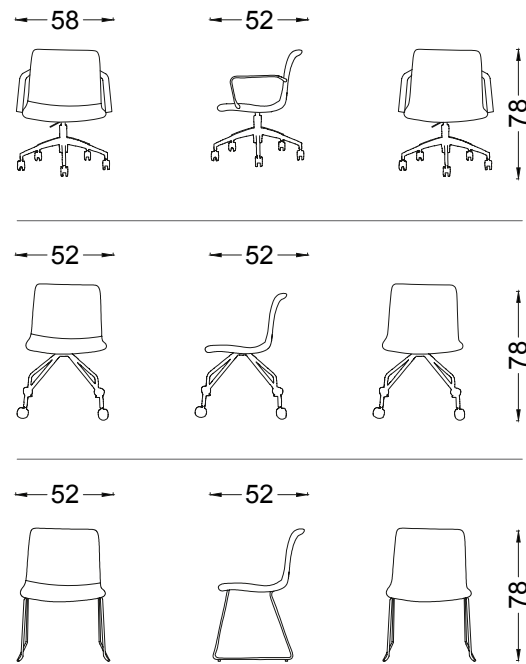

# ORBIT CHAIR



- \* Electrostatic paint coated or matt anodized aluminum injection star feet with height adjustment. (Orbit study model)
- \* Electrostatic painted metal four feet with plastic moving wheels. (Orbit meeting model)
- \* Single-arm Tilt mechanism that allows up-down movement.
- \* Artificial leather or fabric upholstered metal carcass on cast polyurethane body.

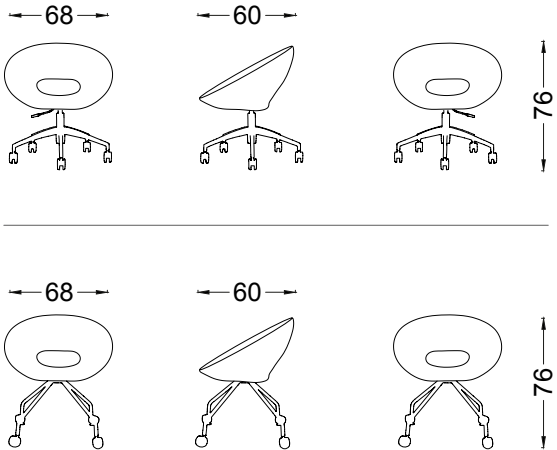

# KUKA OTTOMAN



- \* Over metal carcass polyhuretane cast foam body.
- \* Rotary plastic legs with wheels.
- \* Artificial leather - fabric options.

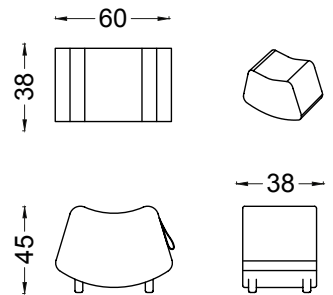



# TOY OTTOMAN



- \* Over metal carcass polyhuretane cast foam body.
- \* Adjustable metal bingo leg.
- \* Artificial leather - fabric options.

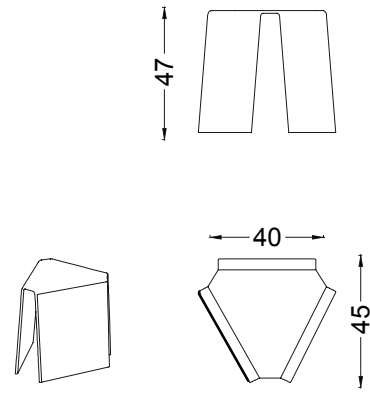

# ROY CHAIR & STOOL



- \* Over metal carcass polyhuretane cast foam monoblock body.
- \* Polished beech massive leg. (BYB200)
- \* Elektrostatic paint or chrome coating metal profile leg.
- \* Artificial leather - fabric options.

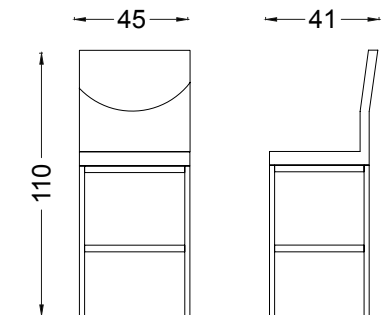
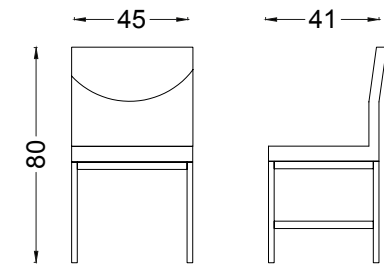

# IKA STOOL



- \* Polished oak massive wood skeleton.
- \* Upholestry artificial leather or fabric over ply wood font.
- \* Aluminum step metal.

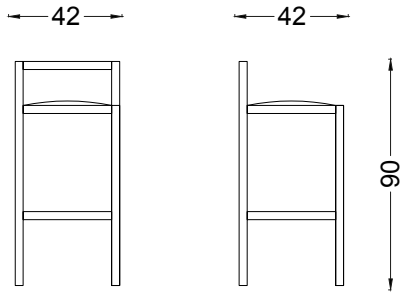

# TIN COFFEE TABLE



- \* 8mm Melamine side table top.
- \* Elektrostatic paint coating 10\*10 cnc twist metal llama side table leg.

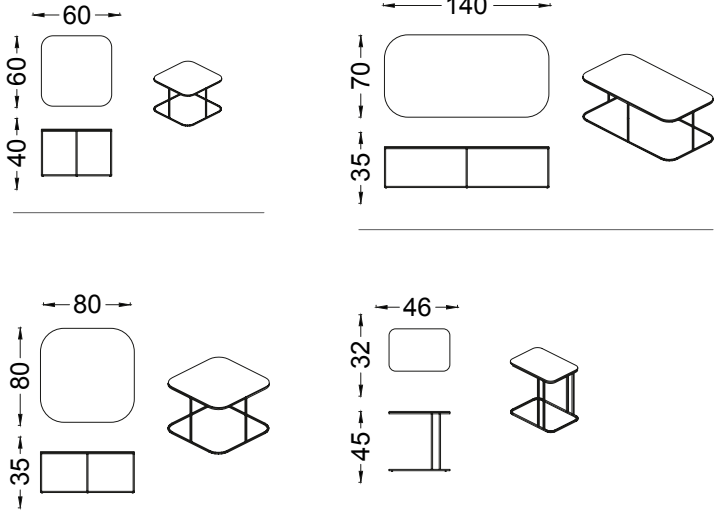

# GITO COFFEE TABLE



- \* Polished oak veneered side table top.
- \* Elektrostatic paint coating 3mm dkp metal sheet leg.
- \* Polished oak massive body of side table.

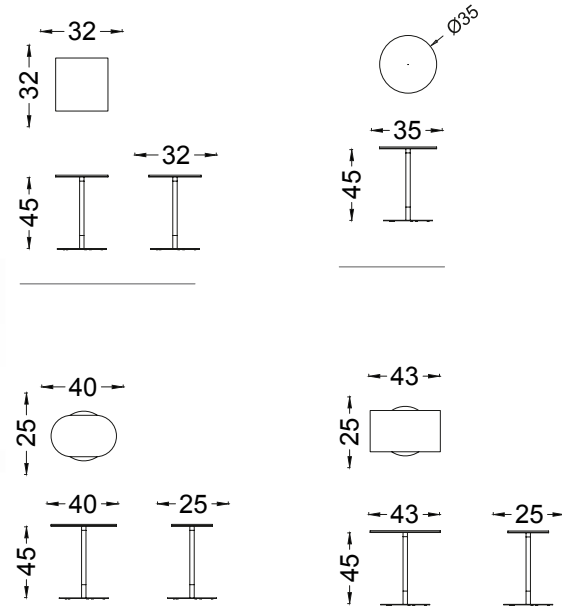

# LINK COFFEE TABLE



- \* 18mm Polished wood veneer side table top.
- \* 50\*20mm elektrostatic painted metal profile leg of side table.

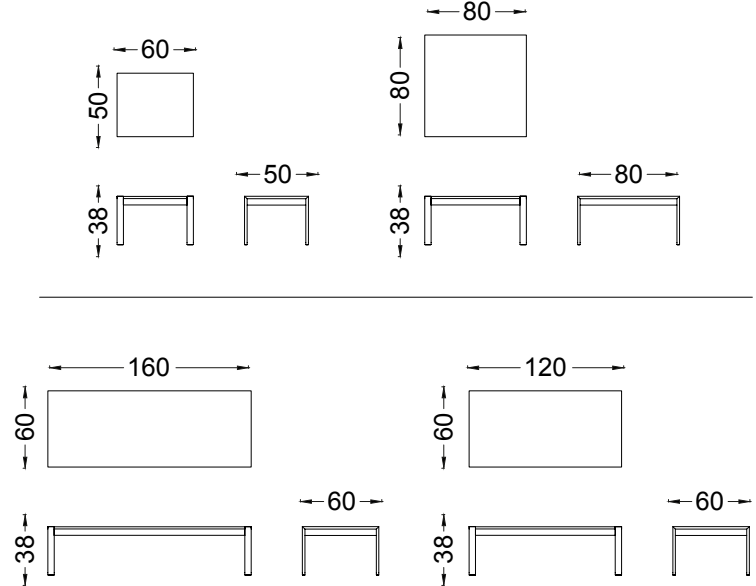

# KULA COFFEE TABLE



\* Polished wood veneer side table top.  
\* Lacquered over Beech massive leg of side table.

# SAL COFFEE TABLE



\* 8mm melamine side table top.  
\* Elektrostatic paint or chrome coating Cnc twist 13mm diameter metal pipe side table legs.

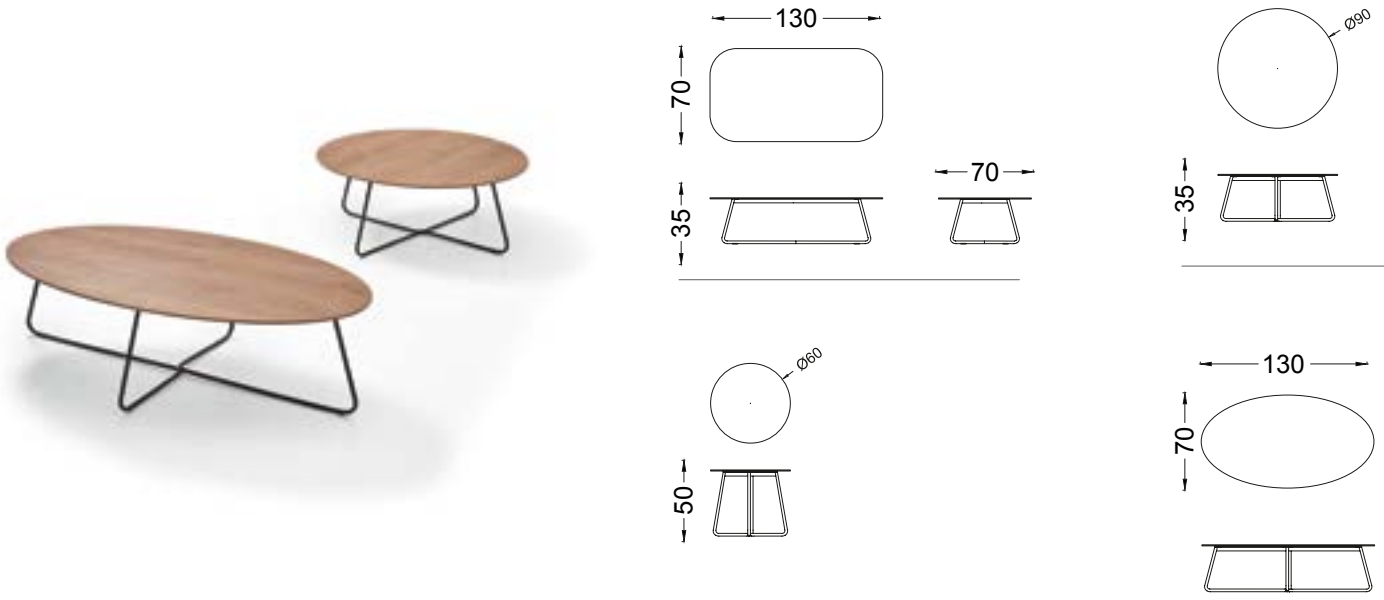



# TAV

## COFFEE TABLE



\* Polished wood veneer side table top.  
 \* Electrostatic paint or chrome coating  
 40\*10mm metal profile leg of side table.

